

# **Owners Manual**

## **Pro-Line Walkarounds**

### **Models:**

- \* 201 Walkaround
- \* 211 Walkaround
- \* 220 Cuddy Fish
- \* 231 Walkaround
- \* 251 Walkaround

# Table of Contents

## II Introduction Pg 4

Dealer / Customer responsibilities

Registration

Insurance

## III Safety Pg 5

Regulations

Equipment

Passenger safety

Rules of the road

Hazardous conditions

Alcohol

## IV Controls, and Systems Pg 6

Ignition

Choke

Safety shut down

Shift / Throttle / Trim

Steering

Instruments: Fuel Gauge, Oil Pressure., Water Temperature, Volt,  
Tachometer, Speedometer, Trim, Options

Switches: Windshield Wipers, Bilge Pump, Blower, Lights, Trim, Trim

Tabs Systems: Fuel/ Oil, Fresh Water, Sea Water, Head/ Waste, Electrical  
(ac, dc, gen set), Water, AC/ Heat, After Market Accessories

## V Trailering and Launching Pg 14

Classification and Capacity

Hitch

Load Distribution

Launching and Retrieving

## VI Operation and Performance Pg 16

Loading

Fueling

Starting

Torque

Trim

Prop

## VII Service and Care Pg 20

Fiberglass / Gelcoat

Marine growth

Plexiglas  
Stainless Steel/ Aluminum  
Canvas  
Upholstery: Vinyl, Fabric  
Corrosion Protection  
Winterization, Storage, Mooring

VIII Appendix Pg 24

Boat ID  
Trouble Shooting Chart  
Nautical Terms  
Warranty  
Wiring Diagrams

## **List of Illustrations**

Fig. 1 Helm Pg 7  
Fig. 2 Bilge / Fuel Pg 10  
Fig. 3 Trim Tabs Pg 11  
Fig. 4 Water Systems Pg 13  
Fig. 5 Trim Condition Pg 19  
Wiring Diagrams Pg 28

# Introduction

Congratulations! You are now the proud owner of a new Pro-Line walkaround. Welcome into our ever expanding family of satisfied Pro-Line owners. Every journey lets you enjoy the excitement of a new adventure. Your new Pro-Line is more than just a boat it's a way of living.

Pro-Line employee commitment to excellence has enabled us to create a superior fishing craft, providing you with comfort, performance, safety and dependability. All of our boats comply with U.S. Coast Guard (USCG) safety standards, and are designed, engineered and crafted in accordance with recommendations and guidelines set forth by the National Marine Manufacturers Association (NMMA) and the American Boat and Yacht Council (ABYC).

This manual (to be kept onboard your Pro-Line) is designed to provide you with information necessary for safe, efficient operation and care of your new Pro-Line. To maximize your enjoyment and safety take the time now to carefully review the documentation in your owners pack and this manual, and really get to know your boat.

## Dealer Responsibilities

Your dealer's responsibilities include but are not limited to:

- \* Pre-delivery verification of proper rigging and operation.
- \* Providing adequate orientation in general operation of your Pro-Line including explanation of specific safety considerations regarding the use of systems and components.
- \* An explanation of owners packet literature and warranty registration cards for all separately warranted equipment and accessories.
- \* Explaining local and out of area service procedures during and out of warranty periods.

## Customer Responsibilities

- \* Be proficient in boat handling and safety. - **THIS MANUAL IS NOT INTENDED TO PROVIDE COMPLETE TRAINING ON ALL ASPECTS OF GENERAL BOAT OPERATION.**
- \* Read and understand the limited warranty.
- \* Read all literature and instructions and use all equipment in accordance therewith.
- \* Examine the boat at time of delivery to ensure that all systems are functioning normally.
- \* Learn about and operate boat in accordance with local, state and federal

laws regulations and **registration** requirements.

- \* The owner is legally responsible for all liabilities of operation - secure **insurance protection.**

## **Safety**

Your Pro-Line boat has been constructed with safety in mind, however the ultimate safety of you and your passengers is in your hands. Plan your trips carefully. Tell someone where you are going and when you expect to return.

## **Regulations**

The USCG is the authority of all the waterways. State boating regulations are enforced by local authorities. You are subject to marine traffic laws and "Rules of the Road" for both federal and state waterways, and must submit to boarding if requested by proper authority.

There are many publications available from the Coast Guard concerning regulations, and more. For additional information call the boating safety hot line at 1(800)368-5647.

## **Equipment**

USCG regulations require the following equipment while operating your boat:

- \* Fire extinguisher
- \* Personal Flotation Device (PFD) for each occupant
- \* One throwable PFD
- \* Sound signal device
- \* Navigational lights if operated at night
- \* Sight signal (flare- night, orange flag- day) if operating in coastal waters or great lakes.

In addition, here is a list of suggested equipment you should have aboard your Pro-Line:

- |                                     |                                       |
|-------------------------------------|---------------------------------------|
| * First aid kit and blankets        | * Grounding & sea anchors with line   |
| * Mooring lines and fenders         | * Bailing device                      |
| * Combination oar / boat hook       | * Tool kit and lubricant              |
| * Spare prop, nut & washer          | * Spare fasteners, hose clamps, plugs |
| * Spare fuses and bulbs             | * Binoculars or telescope             |
| * Local charts and compass          | * Water proof flashlight              |
| * 2 way radio (with proper license) | * EPIRB                               |
| * Floating key chain & spare keys   | * Navigation device                   |
| * Emergency food and water          | * Water proof matches or lighter      |

## **Passenger Safety**

You are responsible for the safety and conduct of your passengers, make sure:

- \* You instruct passengers on proper use and location of PFD's - children and non-swimmers should wear one at all times.
- \* When underway each passenger is in a safe location, and keeps the boat balanced.
- \* At least one other person knows how to operate the boat in case of emergency.
- \* They are aware of dangers of the prop, and the possibility of sudden maneuvers and jolts.

## **Rules of the Road**

Know and use the rules of the road, the information here is only a brief overview.

For detailed information contact the USCG.

Audible warning signals:

- \* One short horn blast: starboard course change.
- \* Two short horn blasts: port course change.
- \* Three short horn blasts: astern operation.
- \* Five horn blasts: doubt about previous signal, or danger.
- \* One Five second blast every minute: for fog operation

When overtaking give-way vessel announces intention with horn blast(s) and waits for same response, then completes maneuver.

When approaching head on both boats give way after giving appropriate horn blast. (preferable to starboard)

When crossing a vessel converging from starboard has right of way, port vessel gives way (both acknowledge with one short horn blast).

Know and observe navigational buoys and markers.

Give way to craft under sail.

## **Hazardous Conditions**

Keep track of weather developments and avoid hazardous conditions if possible.

When forced to operate your Pro-Line in storm conditions:

- \* Wear PFD's
- \* Stow loose gear and equipment.
- \* Place heavy items as low as possible
- \* Head for the easiest to reach safe location.
- \* Reduce speed.
- \* If power fails rig a sea anchor off the bow (an empty ice chest in a pinch).
- \* Stay with boat if it capsizes, unless it is burning out of control.

## Alcohol

Simple, don't drink and drive. If you have been drinking have someone drive who has not been drinking.

## Controls and Systems

Pro-Line Boats offer many different engine and drive unit choices, therefore the information in this manual is general in regards to engine and controls. Refer to the engine/ drive manuals in your owners packet for additional, specific information.

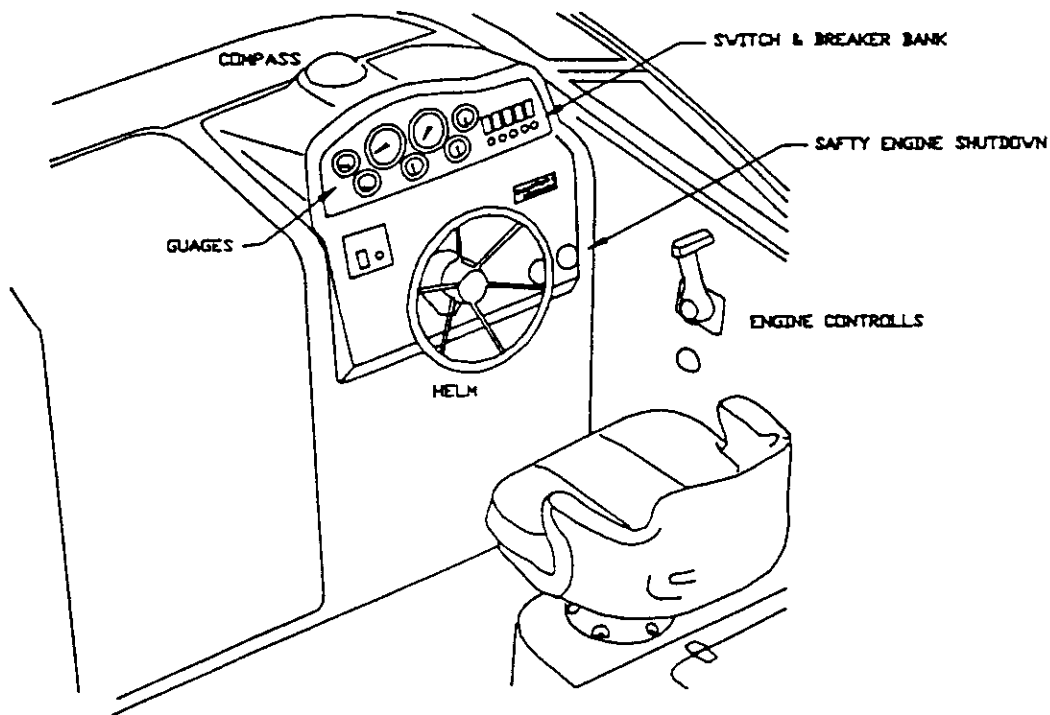

<Fig. 1 helm>

## Ignition

The ignition switch has three positions; off, on, start. To start the engine, turn the key clockwise against the spring pressure to the start position, as soon as the engine starts release clockwise pressure allowing spring tension to return switch to the on position. If the engine fails to start in 5 seconds of cranking allow the starter to cool 10 seconds and repeat.

## **Choke**

The choke is only used to aid in starting a cold engine. Operation varies with manufacture, consult your engine manual.

## **Safety Shut Down**

The Safety shut down switch shuts off the engine in case the operator is thrown from the boat. To ensure proper function always attach the lanyard securely to the operator.

## **Shift/ Throttle/ Trim**

Your Pro-line can be ordered with several different shift/ throttle systems. Refer to the owner's packet to find the manual pertaining to your particular installation.

## **Steering**

Your Pro-line is equipped with a push pull cable or a hydraulic steering system. When the steering wheel is turned a cable is extended or retracted (or fluid is pumped to the steering cylinder), causing the boat to turn.

Periodically check the fluid level and top off if necessary. Beware of adding too much fluid especially if the ambient temperature is cold because expansion could cause leaking or damage to your system (refer to manual in packet). Every 24 hours of operation check all nuts, caps, and hose fittings for tightness. Check that the hoses or cables are not chafing, or kinking on sharp corners. Also check that ends are not damaged or distorted by clamps.

The fluid should be changed yearly under normal conditions, twice yearly for heavy use.

If your steering does not operate properly check the drive for entanglement, then fluid level, and hoses / fittings for leaks, damage or corrosion.

## **Instruments**

Your Pro-Line's instrumentation will vary from model to model and engine to engine, therefore the following descriptions are general - refer to your engine manual for specifics.

### **Fuel Gauge**

Differences in temperature, humidity, speed and trim can affect the actual accuracy of this gauge in service. It is important to verify the fuel flow in gal./hr. for your boat and make note of your gauge position with respect to time for different RPM settings. No gauge can give 100% accuracy. If you notice unusually high or low fuel consumption, investigate further to see if the engine is using more fuel than normal.



### **Oil Pressure**

This is a very important instrument, oil pressure is vital to engine life. Generally readings of 10-15 psi at idle and 15 to 25 psi at cruise are sufficient to protect your engine. If you notice abnormally low or high readings, check and correct oil level, if condition persists consult your dealer. If you lose oil pressure: shut down the engine immediately, find and correct the problem before restarting engine, running your engine without oil pressure will result in serious and costly damage.

### **Water Temperature**

The water temperature gauge indicates the internal water temperature of your engine. Your engine is equipped with a thermostat to quickly bring the engine up to its optimum operating temperature range of 150 to 170 degrees f. All outboard engines are also equipped with a audio alarm system indicating a overheat condition, if the gauge or alarm indicates a over heat condition immediately shut the engine off, lift the drive and inspect water intakes for obstructions such as aquatic vegetation or mud. After finding the source of the overheating, restart engine and confirm water flow, if water does not flow within five seconds shut the engine off.

### **Volt**

The volt meter indicates battery voltage; normal reading is between 12 to 15.5 volts. A low reading indicates too heavy of a load or a dysfunction in the charging system. Too high of a voltage indicates a fault of the charging circuitry and continued operation will damage the battery.

### **Tachometer**

The tachometer indicates the revolutions per minute (RPM) of your engine. Do not operate the engine beyond the limits stated in your engine manual. Abnormally low tach. readings (for a given throttle setting) indicates loss of power, or a prop entangled with weeds or trash- check the prop first. A reading higher than normal indicates a ventilating or cavitating prop, or prop/ drive damage.

### **Speedometer**

The speedometer indicates the speed of your boat in Miles per hour (MPH). The gauge operates by sensing water impact pressure from the pitot tube mounted on the transom. (or integrated into the lower drive unit ). If the gauge fails to give a reading suspect a blocked pickup.

### **Trim**

The trim gauge indicates the in (down) and out (up) position of the drive unit in relation to the hull. (see Trimming your boat p.17 )

### **Options**

Optional instrumentation for your Pro-Line includes: fish locator / depth finder, VHF radio, GPS / LORAN navigation aids, etc. Refer to the manuals supplied.

## Switches

### Windshield Wiper

For operation in rain or adverse conditions, optional windshield wipers enhance visibility from the helm and therefore safety.

### Bilge Pump

Your Pro-Line is equipped with an automatic bilge pump system with a manual override. The pump is located at the aft end of the bilge at the keel. The automatic float switch is wired directly to the battery terminal through an in-line fuse. Keep the bilge area clean and free from debris that could clog ports. The helm switch overrides normal automatic operation. Breakers are located at the helm, fuses on the transom.

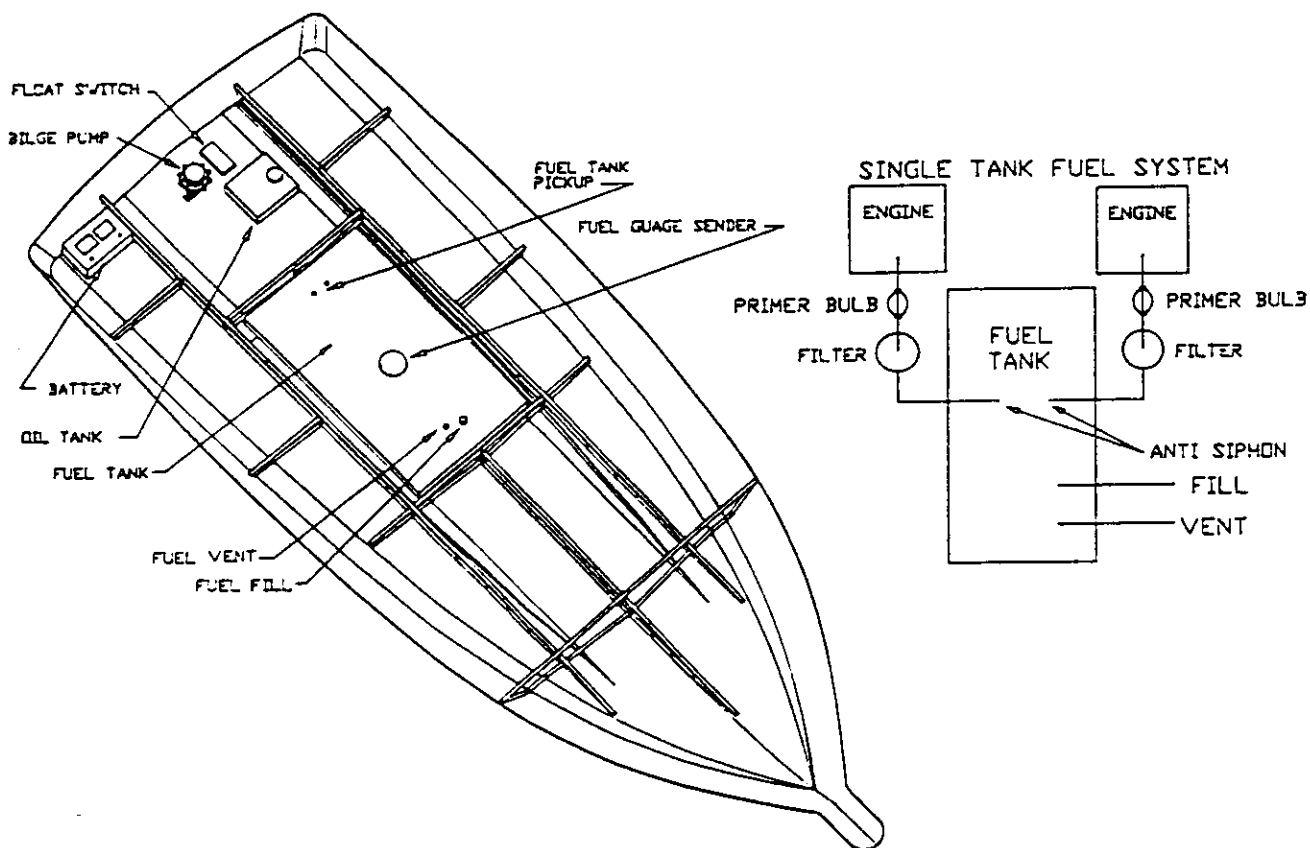

<Fig. 2 bilge/ fuel>

## Blower

Pro-Line's equipped with an inboard mounted engine have a bilge blower to rid the bilge of explosive fumes. Always operate the blower a minimum of four minutes and check bilge for fumes before starting the engine. Operate the blower whenever engine is running and the boat is stopped (or operating at low speed). At speed, air blows through the bilge keeping fumes under control and blower operation is unnecessary.

## Lights

For operation at night your Pro-Line is equipped with navigation, and anchor lights to indicate your position to other boaters. While running after dark the nav. lights are required to be on and visible to other boaters, visually verify operation and lack of obstructions.

Lights are also provided for the cockpit, bait-well, helm and cabin, as well as spreader lights.

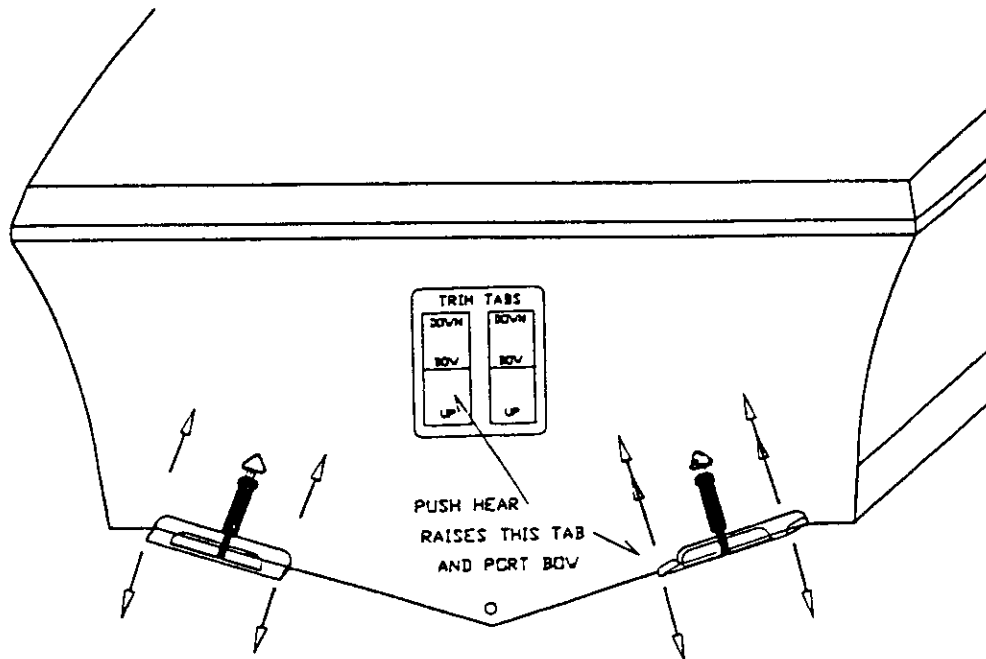

<Fig. 3 trim tabs>

## Trim Tabs

The optional trim tabs operate independently up or down to correct for differing conditions of wind or load.

Before the boat is underway depress the bottom half of both switches until the tabs are fully elevated (bow up position) while underway and in open water clear of other boaters, depress the top half of both switches in half second bursts to achieve the desired degree of bow down trim.

To correct a port list give the top half of the port switch a series of bursts until the

list is corrected. To avoid over trim allow a few seconds between bursts to allow the boat to respond (if you over trim simply give the over trimmed tab a burst or two in the opposite direction).

To trim the bow down push the top half of both rocker switches in half -second bursts.

Warning: trim tabs can cause a dramatic change in the attitude and heading of your boat, adjust them only when in open water, clear of any obstructions, and then only in small increments.

### **Breaker Switches**

The wiring on your Pro-Line is protected by circuit breakers or fuse. If a device stops working first suspect the circuit breaker is tripped (or fuse blown).

A tripped breaker will protrude from its set position, indicating that the circuit has been overloaded. Turn off the device(s) on the circuit then reset the breaker by pushing in once. If the breaker does not reset or if it resets and then pops out again after the device is turned back on, then a short circuit exists or your device may be damaged, overloaded or faulty, correct the problem and then reset the breaker. If the breaker continues to pop and you are certain the device, switch and wiring are in good repair, either the breaker is too small for the load or is faulty, reduce the load, or replace the breaker.

## **Systems**

### **Fresh Water System**

The water pumps on your Pro-Line are controlled on demand by a drop in water pressure. The master switch located either at the helm or in the cabin switches the pumps unconditionally off. The switch should be kept off while not in use, or unattended.

### **Sea Water System**

The bait-well/ wash down switch controls a common demand pump. A valve directs flow either to the wash down outlet or through the bait well. Sea cocks on all below water line fittings should be closed when not in use.

### **Head / Waste**

If your Pro-Line is equipped with a portable or electric head refer to the manual supplied in your owner's packet.

The electric head utilizes a macerator / waste pump and clean-out fittings for dock side operation. A sea valve is provided for offshore operation. A raw water pump with an intake seacock is used for flushing.

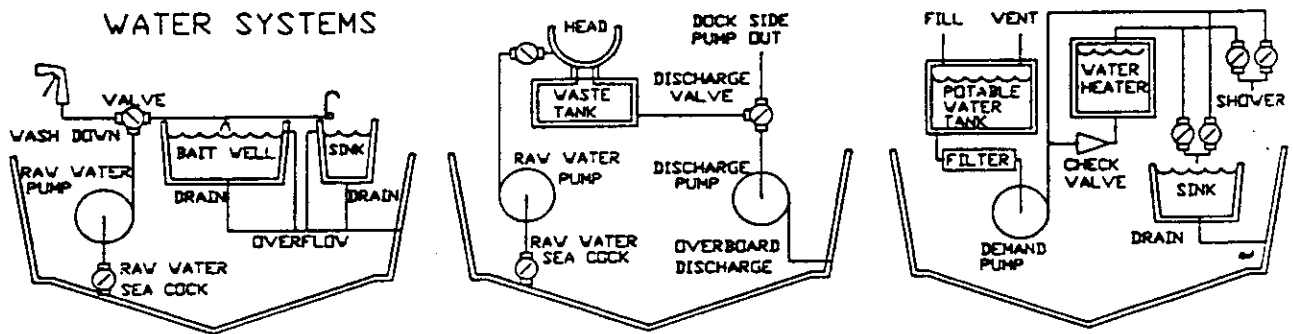

<Fig. 4 water systems>

### Fuel / Oil System

The fuel tank on your Pro-Line is made of heavy gauge aluminum with internal baffling to minimize sloshing. The tank is vented overboard, inspect the vent for obstructions regularly. 'Deck plate' access ports are placed over the hose connections and the sending unit. Inspect the hose connections on a regular basis and if you notice fuel odor or see fuel in the bilge.

Pro-Line boats equipped with oil injected outboard engines have an on board oil tank, ensure that the tank is well stocked with the recommended 2 stroke oil - refer to your engine manual. It is imperative that the oil supply remain clean and uncontaminated by water or dirt, check to make sure that the oil lines are free from leaks kinks, and chafing.

### Electrical

#### Alternating Current

Shore power is used for the operation of AC devices like your air conditioner, microwave, battery charger, hot water heater and 110v outlets for other appliances. Shore power also operates your refrigerator (12v at sea). The panel is located in the cabin, if the reverse polarity light is on, unplug shore power and do not use it until this potentially dangerous situation is corrected.

## **Generator**

If your Pro-Line is equipped with a generator you can enjoy the use of your AC appliances while at sea. The generator energizes your AC electrical system by burning fuel from the fuel tank (starboard on dual tank models). Refer to the generator manual for maintenance requirements.

## **Direct Current**

12 volt direct current provides electrical power for all lighting, pumps, electronics, and DC devices. fuses are located on the transom, breakers at the helm. Battery selector switches are on the transom for battery isolation, parallel operation and disconnect. **Caution:** To avoid possible alternator / battery damage on twin engine installations, ensure that the optional dual battery switches are never left so both engines are connected together (never leave a switch on 'both'). The preferred switch position is port engine to port battery, starboard to starboard.

# **Trailer and Launching**

Consult your trailer manufacture for specific information relating to your particular trailer. Pro-Line does not make or recommend the use of any particular trailer.

Make sure the trailer you use is certified.

Consult your state authority for state regulations pertaining to trailering a boat.

Use the following towing check list:

- \* Check brakes if equipped.
- \* Check springs and under carriage for cracks, loose parts and fasteners.
- \* Ensure tires are inflated to proper pressure, and in good condition.
- \* Check wheel bearings and lug nuts.
- \* Verify light and signal operation.
- \* Make sure boat is tied down from bow and stern eyes.
- \* Stow bimini top and other items likely to blow off.
- \* Carry a spare tire and tools for changing. (spare bearing and race set for long trips)
- \* Securely brace O/B motors.
- \* Go slow over bumps.
- \* Check tires and hubs often for excessive heat, service if required.
- \* When backing have an assistant watch blind spots and guide with hand signals.

## **Capacity**

The trailer you choose should be a proper match for your boat with regard to capacity and hull design, consult your dealer when making your selection. The tow vehicle must have sufficient towing capacity for the combined load of boat, trailer

and accessories. Check the certification label on the forward port (left) side of your trailer to ensure that it has adequate gross vehicle weight rating (GVWR) for the combined boat and trailer.

### **Hitch**

Ensure that the hitch in the tow vehicle is rated for the GTW or greater, and that the ball size matches the trailer receiver.

### **Load Distribution**

Generally speaking the tongue weight should be from 5 to 10 % of the GVWR. Make certain that the hull is evenly supported along the length and width with no load concentrations. Make sure that the bottom of the transom is supported and not hanging past the end of the trailer. Load the boat so it is centered side to side, and straight on the supports.

### **Launching and Retrieving**

#### **Pre- Launch Check List-**

- \* Install drain plug.
- \* Remove covers and tie downs. (leave bow winch strap in place)
- \* Place lines and fenders as needed.
- \* Disconnect lights to avoid shorting.
- \* Verify that safety equipment is aboard.

#### **Launching-**

- \* If possible use a lookout.
- \* Back down the ramp until wheels are under water or the stern of the boat just starts to float ( keeping perpendicular to the shore)
- \* Loosen bow strap, board the boat, lower the drive unit and operate blower 4 minutes.
- \* Start the engine and ckeck the bilge for leaks.
- \* Remove winch strap from bow eye.
- \* Back boat off of trailer.
- \* Dock the boat and park the tow vehicle.

#### **Retrieving-**

- \* Back down the ramp so trailer is half submerged.
- \* Carefully line up boat, slowly maneuvering with short bursts of power.
- \* When the keel is centered and boat is just touching the trailer, winch (or smoothly apply power) until the boat **eases** to rest on the bow rest.
- \* Secure the bow strap.
- \* Haul the boat out of the water and park out of the way of others.
- \* Remove the bilge plug.
- \* Rinse off salt water if fresh water is available (or as soon as possible

otherwise).

- \* Stow equipment and canvas, affix tie downs and covers.
- \* Hook up trailer lights and verify operation.

## **Operation and Performance**

### **Loading**

The capacity plate states the maximum persons and the maximum weight in pounds for persons, engine and gear that the boat will safely accommodate under normal conditions. These load capacity ratings are computed using USCG formulas. For operation in rough and adverse conditions reduce the boats load to permit safe operation.

The performance of any boat is a function of the amount of load carried, great loads reduce performance. Depending upon conditions and what engine / hull combination you have selected, your boat may not be able to stay on plane when loaded to its maximum rated capacity.

When loading your Pro-Line always:

- \* Maintain a balance both port to starboard and bow to stern.
- \* Keep heavy items as low as possible.
- \* When boarding step (never jump) into the boat one at a time.
- \* Pass gear from the dock to someone in the boat, do not carry gear while boarding.
- \* Never allow passengers to ride with feet hanging over the side of the boat.
- \* Do not allow passengers to sit or stand on top of the stern, or gunwales of the boat.

### **Fueling**

Due to the explosive nature of gasoline certain precautions must be observed when fueling up.

#### **Before Fueling-**

- \* Secure the boat to the dock with adequate moorings.
- \* Turn off engine and any equipment having brush type (spark producing) contacts.
- \* Close cabin, doors and hatches so fumes don't enter boat.
- \* Disembark all persons not necessary for the fueling operation.
- \* Prohibit all smoking and open flame on board and nearby.
- \* Have a fire extinguisher close by.

#### **While Fueling-**

- \* Keep nozzle in contact with fill opening to minimize the chance of



sparks.

- \* Do not leave unattended.
- \* Do not spill fuel.
- \* Do not over fill, filling a tank until fuel is vented is dangerous. Allow room for expansion.

#### **After Fueling-**

- \* Close fill opening.
- \* Wipe up any spilled fuel. Dispose of rags on shore.
- \* Open cabin door, ventilate boat and run blower (stern drive & inboard) for a minimum of four minutes before starting.
- \* Check for fumes in bilge, continue to ventilate if present.
- \* Verify proper fuel selector valve position (dual tanks only).

### **Starting**

Follow the information in your engine manual if it deviates from the following instructions.

#### **Before Starting Engine-**

- \* Ventilate all enclosed space, and run blower a minimum of 4 min.
- \* Visually inspect bilge for raw fuel, smell for vapors.
- \* Visually make sure propeller is clear of obstructions or swimmers.
- \* Make sure engine cooling water intakes are submerged.
- \* Lock helm seats to face straight forward.

#### **For a Cold Engine-**

- \* Pump the throttle two or three times to prime (stern drive only).
- \* Advance the throttle approximately 1/4 open (out of gear).
- \* Activate the choke while cranking.
- \* Release the choke as engine smooths out (give the choke a short burst if rough).

#### **For a Hot Engine-**

- \* Leave the throttle closed and choke off.
- \* If engine fails to start in 5 seconds, partially open throttle (out of gear) and try again.
- \* If flooded, keep throttle open for a few minutes and then crank. When engine starts close throttle smoothly as the engine clears to prevent over revving.

After your engine starts make sure to observe a few basic rules to ensure that the engine is functioning properly:

- \* Verify oil pressure and water circulation
- \* Check the water temperature gauge for the first few minutes to make sure the engine is warming properly

- \* Check for leaks especially fuel, shut down and correct if found.
- \* Follow the break-in procedures for your engine.
- \* After engine is warm and after the necessary break-in, drive the boat at full throttle for a few moments (if conditions permit) to verify that the engine is developing full RPM.

## **Torque**

The twisting force that the engine applies to the prop lists the hull of your boat in the opposite direction the propeller is turning. For a large engine or light hull this list can be considerable. A listing hull has more drag on the side that is deeper in the water causing boat to turn in the direction of the list. The trim tab on your out drive should be adjusted to counteract the torque steer for the load and speed the boat is most often operated at. Consult your engine manual for specific information on trim tab adjustment. Torque induced list can also be corrected by shifting the load in your boat. Twin engines, when counter rotating, cancel the torque and no correction is required.

## **Trim**

The power trim system allows the operator to raise and lower the drive unit or motor through out a infinite number of settings between its upper and lower limits. For every throttle setting there is a trim setting that will yield optimal speed, stability or maneuverability.

For most conditions the best all-round performance is obtained when the bow of the boat is slightly out of the water.

general trim down (or "in") characteristics are:

- \* Starting position for best acceleration to plane.
- \* Lowers bow in the water providing better stability and ride in rough water.
- \* Reduces boat speed and economy due to increased drag of hull and drive.
- \* More spray over bow.

General trim up (or "out") characteristics are:

- \* Raises the bow of the boat in the water, resulting in less hull in the water.
- \* Greater speed and economy for a given throttle setting.
- \* Greater maneuverability (provided prop does not ventilate during the maneuver)
- \* In excess, the reduced stability can lead to bouncing, porpoising and propeller ventilation.

In addition to providing ideal boat performance, the power trim enables the motor or drive unit to be raised (tilted up) for trailering, beaching, and launching.

The electric motor that drives the hydraulic pump is protected by an internal

thermal circuit breaker that interrupts the power when overheated. Avoid continued pressure on the switch after the unit has reached the limits of travel (you can hear the difference in sound as the pump strains against the increased load).

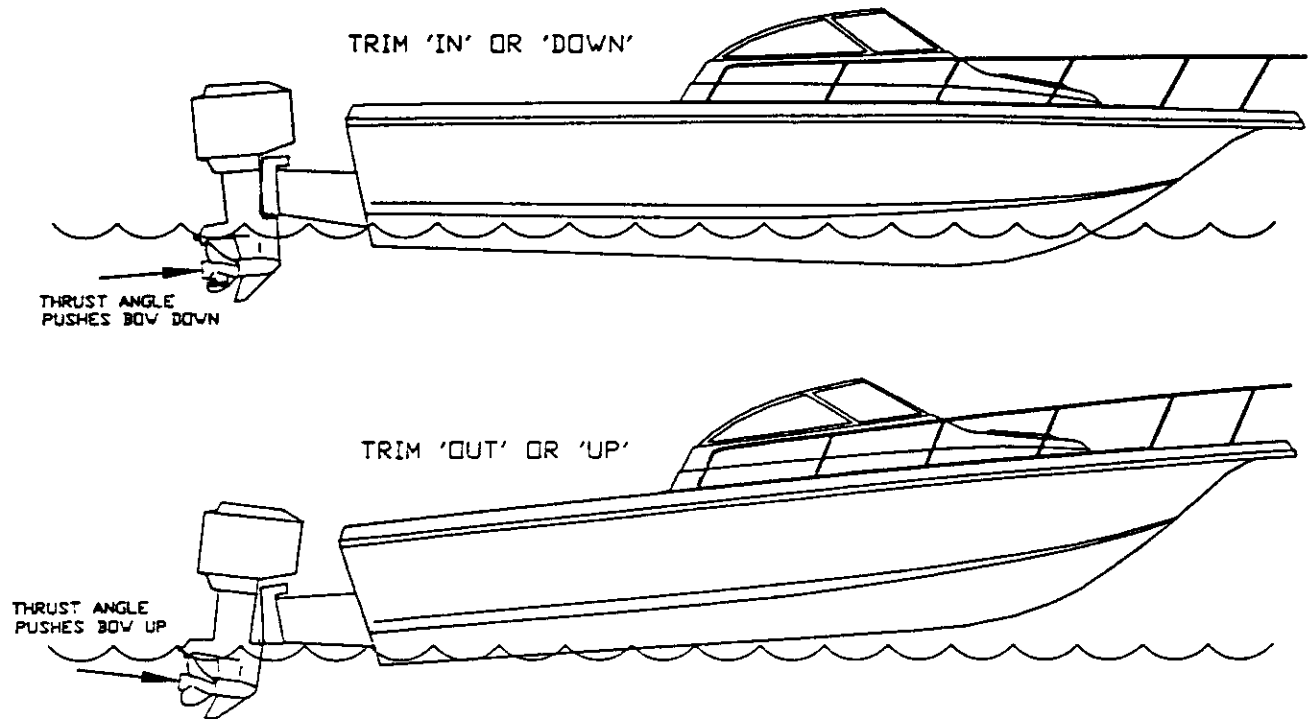

<Fig. 6 trim condition>

## Prop

If your Pro-Line was ordered with a factory installed engine it will have a propeller that has been performance tested to provide the best all-round performance for your engine /hull combination at sea level.

In some situations, it may be desirable to re-prop your Pro-Line to enhance desired performance needs- for instance:

- \* Decreasing pitch will enhance acceleration and power at high loads.
- \* Increasing pitch will increase speed at light loads.
- \* Decreasing diameter will compensate for loss of power at high altitudes.

\* Increasing diameter results in higher efficiency at low speeds at the expense of top speed and acceleration.

When re- propping to a lower pitch or smaller diameter be sure not to over rev the engine at top speed, engine damage could result.

Operating your engine with a damaged prop will decrease top speed, increase fuel consumption and may introduce undesirable handling characteristics. The vibration caused by running a damaged prop could cause costly damage.

## **Service and Care**

To enjoy trouble free use of your Pro-Line follow the recommended procedures and instructions

relating to the service and care of your boat. Failure to follow the following maintenance practices will result in shorter life of your equipment and may void your warranty.

Much of the installed equipment on your Pro-Line is separately warranted, follow the care instructions found in your owners packet to keep these warranties in force.

Your engine manual contains service information relating to your particular engine installation. follow the provided recommendations for trouble free service, and to preserve your warranty.

### **Fiberglass / Gel Coat**

The fiberglass hull, inner liner, console, deck and some other molded components on your Pro-Line consist of a Fiberglass shell integrated with a gel coat finish. The gel coat (perhaps colored) presents a smooth glossy surface finish that is associated with fiberglass. In areas receiving traffic the gel coat is molded with a rugged nonskid surface, in other areas it may be painted or striped with a accent for styling purposes.

For lasting shine keep your boat clean, wash all gel coated and painted surfaces regularly with clean fresh water, wax the surfaces to maintain the luster. If the boat is kept covered or out of the sun most of the time a seasonal waxing will suffice. For constant exposure to the sun frequent applications of wax will delay oxidation of the surface.

If the surface takes on a dull appearance that is not restoreable by waxing, hand buff with a rubbing compound such as Dupont No. 7, or power buff with Mirror-Glaze No 1 then wax.

Caution: when power buffing use care not to leave swirl marls or "burn" the surface, you may want to leave this to a professional.

Gel coat surfaces are resistant to deep stains. Common surface stains can be

removed with diluted household detergents, provided they don't contain ammonia, chlorine or abrasives. Do not use acetone or any ketone solvents, stubborn stains can be removed with alcohol or kerosene provided they are washed off promptly with mild detergent and water.

The gel coat on your Pro-Line is approximately 25 mil thick. If a deep gouge to the surface occurs that goes all the way through the gel coat into the fiberglass it must be repaired promptly to avoid further damage. Your dealer is best equipped to handle this repair and achieve good bonding and color match. There are many different gel coat repair kits on the market for this use however results obtained may not be satisfactory.

Minor scratches and deep stains that do not penetrate the gel coat can be lightly wet sanded with 600 grit, buffed and waxed to remove.

For damage to fiberglass that goes deeper than 1/16 inch see your Pro-Line dealer.

### **Marine Growth**

If marine growth is a problem consult your dealer about an anti fouling finish for the portions of the hull below water line. When moored in salt or brackish water it is recommended that you haul the boat out and scrub the bottom every 30 days to prevent great acclimation of marine growth.

### **Plexiglass**

To clean Plexiglass, rinse with fresh water to clean as much grime as possible. Use your bare hand with lots of water so you can feel any grit and avoid grinding it in to the surface as you dislodge it. A soft clean cloth may then be used with a non abrasive mild detergent. Rinse and blot dry with a clean dry chamois.

Grease and oil may be removed with kerosene, hexane or white gas. ( not gas you burn in your boat, car or lawnmower ).

Never use, solvents like acetone, silicone spray, benzine, carbon tetrachloride, dry cleaning fluid, lacquer or paint thinner, or any chlorinated solvent, on Plexiglass, since they dissolve the material.

### **Stainless Steel / Aluminum**

Stainless steel is used on bow rail and deck fittings on your Pro-Line. Stainless is corrosion resistant but not corrosion proof. If used in contact with sulfides, chloride salts, or rusting metals stainless will show rust spots, discolor or corrode. The grain structure of stainless, when modified by welding processes has increased susceptibility to micro- corrosion (invisible to the unaided eye) and embrittlement. Proper care will preserve the weld strength and beauty of your stainless:

- \*Always clean frequently with soap and water, most glass cleaners work well.

- \*Always protect with a wax or oil film especially around welds to guard

against micro- corrosion cracking and rust spots.

- \* Always remove rust spots as they appear with brass, silver or chrome cleaner.
- \* Never use coarse abrasives like sandpaper or steel wool on stainless, as these can cause rusting.
- \* Never clean with acids or bleaches.
- \* Never permit contact with iron, steel or other metal which could cause rust or corrosion.

## **Canvas**

Cleaning: Brush the canvas with a soft bristle brush and hose down at regular intervals to remove bird droppings, dust and dirt particles. It may be washed with a mild solution of Lux or Ivory soap and Borateem in lukewarm water (less than 100 deg. F.) **DO NOT USE DETERGENTS.**

For more stubborn stains soak the canvas in a solution of 4oz. clorox, 4oz. Ivory soap and one gallon warm water, for about 20 min. Rinse with cold water.

Note: If the water repellence is lost due to cleaning, apply a water repellent treatment as necessary

The canvas may be washed in a automatic washing machine set on 'cold' using 2 cups bleach 1 cup Ivory flakes. **DO NOT DRY IN A DRYER, LINE DRY ONLY** to prevent shrinkage.

If canvas is dry cleaned re treat with water repellent.

Storage: Do not fold or store any canvas while wet. All canvas should be rolled or folded when dry and kept in a clean dry location.

## **Upholstery**

### **Vinyl**

An occasional wipe down with mild soap and water is all your interior and exterior vinyls need to remain in good condition for many years. We do not recommend the use of any special cleaners sealers or treatments for interior and exterior vinyls.

Refer to the provided brochure.

### **Fabric**

For all fabrics Use dry cleaning fluid only.

## **Corrosion Protection**

Your Motor / Drive unit has a sacrificial anode made of zinc to mitigate the effects of corrosion causing, electrolysis. Maintain this anode in accordance with the maintenance schedule in your engine manual. If you moor your Pro-Line in salt water for extended periods make sure to check the anti corrosion anode often for operation, make sure the surface is exposed and not caked with corrosion and scale, if the anode is more than 50% eroded renew it

## **Winterization and Storage**

### **Pre-Storage Check List-**

- \* Remove drain plug, keep bow high to drain any water accumulation.
- \* Run a pint of RV antifreeze through bilge pump.
- \* Drain all water from water systems and head, and pump an approved antifreeze through all pumps, valves, drains and lines.
- \* Fill fuel tank and add a stabilizer/ conditioner such as 'STA-BIL' to the gasoline.
- \* Prepare the engine in accordance with manufactures recommendations found in your engine manual.
- \* Treat metal parts with rust inhibitor.
- \* Remove the battery and protect from freezing. Trickle charge overnight once a month.
- \* Place under cover, if on a trailer loosen tie down straps, and unload the tires with blocks.

### **Fitting Out After Storage-**

- \* Check entire fuel system for loose fittings, leaks and damage.
- \* Examine the exhaust system for rust, loose fittings, and leaks (recheck after starting engine).
- \* Clean battery terminals, install battery(s), and coat terminals with deoxidizing agent.
- \* Check all through hull fittings and hoses for obstructions, water tightness and condition.
- \* Test navigation, anchor and other lights for operation.
- \* Check wiring, terminal blocks and plugs for loose connections and corrosion.
- \* Verify switch and equipment operation.
- \* Check line condition and inspect anchor and rode.
- \* Install hull drain plug, clean out any debris from bilge and cockpit.
- \* Remove antifreeze and flush water system.

# Appendix

## Boat Identification Information

Owner: \_\_\_\_\_  
Home Port: \_\_\_\_\_  
Dealer: \_\_\_\_\_  
Boat Name: \_\_\_\_\_  
Registration No: \_\_\_\_\_  
Hull No: \_\_\_\_\_  
Boat Model: \_\_\_\_\_ LOA: \_\_\_\_\_ Beam: \_\_\_\_\_ Draft: \_\_\_\_\_  
Vertical Clearance: \_\_\_\_\_ Weight: \_\_\_\_\_  
Color; Hull: \_\_\_\_\_ Deck: \_\_\_\_\_ Interior: \_\_\_\_\_  
Warranty Registration Date: \_\_\_\_\_  
Fuel Capacity Gal.: \_\_\_\_\_  
Ignition Key No: \_\_\_\_\_  
Radio Call Letters: \_\_\_\_\_ Bat. Voltage: \_\_\_\_\_  
Engine Make & Model: \_\_\_\_\_ HP: \_\_\_\_\_  
Engine S/N: \_\_\_\_\_  
Drive S/N: \_\_\_\_\_  
Prop: Dia: \_\_\_\_\_ Pitch: \_\_\_\_\_ P/N: \_\_\_\_\_  
  
Trailer Make & Model: \_\_\_\_\_  
Trailer S/N: \_\_\_\_\_ GVWR: \_\_\_\_\_  
  
Insurance Company: \_\_\_\_\_  
Agent: \_\_\_\_\_  
Policy No.: \_\_\_\_\_ Phone No.: \_\_\_\_\_



## Trouble Shooting Chart

<b>Problem:</b>	<b>Possible Cause:</b>
Poor speed or fuel economy:	<ul style="list-style-type: none"> <li>*Wrong propeller for load or conditions.</li> <li>*Trim is in to far.</li> <li>*Load is to far forward or to heavy, or boat has taken on water.</li> <li>*Marine growth on hull. Line or anchor dragging.</li> <li>*Fuel is stale or partially blocked, engine is worn, out of tune or under powered.</li> <li>*Improper rigging, air intake or exhaust partially blocked.</li> </ul>
Engine cranks but will not start:	<ul style="list-style-type: none"> <li>*Safety shut down switch lanyard not installed.</li> <li>*Out of fuel, filter is clogged, fuel line kinked, fuel vent plugged.               <ul style="list-style-type: none"> <li>*Water in fuel.</li> <li>*Engine problem. (electrical, fuel pump, blockage, etc.)</li> </ul> </li> </ul>
Engine will not crank:	<ul style="list-style-type: none"> <li>*Drive is in gear (check operation of the throttle release).</li> <li>*Battery is weak or terminals corroded or loose.</li> <li>*Engine or drive damage.</li> </ul>
Engine runs but boat wont go:	<ul style="list-style-type: none"> <li>*Throttle release is engaged.</li> <li>*Disconnected shift linkage.</li> <li>*Damaged prop. or lower drive unit.</li> <li>*Entangled in lines or weeds, or Anchor is down!</li> </ul>
Prop cavities:	<ul style="list-style-type: none"> <li>*Trim out too far, motor to high.</li> <li>*Weeds on prop.</li> <li>*Bow heavy, damage to hull.</li> </ul>
Excessive vibration:	<ul style="list-style-type: none"> <li>*Propeller, engine, or drive unit damaged.</li> <li>*Hull damage.</li> </ul>
Boat won't turn:	<ul style="list-style-type: none"> <li>*Steering unit needs fluid or has trapped air, tiller is Disconnected. (helm turns)</li> <li>*Steering trunion or mechanism jammed, (helm won't turn)</li> </ul>
Electrical problems	<ul style="list-style-type: none"> <li>*Corroded wires, terminals, or plugs (see wiring diagram)</li> <li>*Broken, loose or short circuited wires</li> <li>*Circuit breaker tripped.</li> <li>*Defective switch, device or breaker.</li> <li>*Inline fuse burnt out.</li> <li>*Overloaded circuit.</li> </ul>
Handling problems like:	
Porpoises	*Trimmed out too far, damaged hull (rocker), trim tabs up, stern heavy
Runs wet	*Trimmed in too far, bow heavy, trim tabs down, overloaded for conditions.
Hard ride	*Stern heavy, trimmed in too far, going to fast for conditions.
Lists	*Loaded to one side, trim tabs set wrong, trimmed to far in, fuel tanks uneven.
Overbank in turn	*Trimmed in too far, improperly located load, throttle advanced to far.
Catches in turns	*Damaged hull (hook), stern heavy, trim tabs down.

## **Nautical Terms**

**Abeam:** At 90 degrees to the center line of the boat, exactly to either side of the boat.

**Abaft:** A point on a boat that is aft of another.

**Aft:** Toward the rear of the boat.

**Beam:** The widest part of the boat.

**Bilge:** The lower interior of the hull.

**Bow:** The fore part of a boat.

**Bulkhead:** A vertical partition or reinforcement in a boat usually perpendicular to the keel.

**Chine:** The juncture of the bottom and the side of the boat.

**Chock:** Deck fitting used to guide a line.

**Cleat:** Deck fitting used to secure a line to.

**Deck:** Upper structure of a boat which covers the hull.

**Draft:** The distance the lowest part of the boat projects into the water.

**Fathom:** A unit of measure equal to six feet.

**Freeboard:** The height of the deck above the water line.

**Gunwale or Gunnel:** The juncture of the side of the cockpit, deck and hull.

**Hatch:** An opening used for access to an interior space.

**Head:** Toilet or toilet area in a boat.

**Helm:** Steering wheel or console area of a boat.

**Hull:** The basic structure of a boat, that provides flotation by displacing and excluding water.

**Keel:** The major lengthwise member of the hull, the lowest portion of the hull.

**Knot:** A measure of speed in nautical miles per hour, equal to 1.15 MPH

**Lee:** The side sheltered from the wind.

**Port:** The left side of the boat when aboard the boat facing the bow.

**Scupper:** Duct to drain water from the cockpit, often with a check valve to sea water intrusion.

**Sheer:** The juncture of the deck and the hull, generally covered by the rub rail.

**Starboard:** The right side of the boat when aboard the boat facing the bow.

**Stern:** The back of the boat.

**Stern Drive:** Inboard /outboard I/O drive unit.

**Stringer:** Lengthwise reinforcing members of the hull.

**Transom:** Vertical part of the stern.

**Wake:** Waves produced by a boat moving through the water.

**Windward:** Toward the direction from which the wind is blowing.

**Specifications: 201 211 220 231 251**

<b>Length over all</b>	20'2"	20'11"	22'5"	25'6"	27'4"
<b>Beam</b>	8'0"	8'6"	8'6"	8'6"	8'6"
<b>Draft</b>	15"	15"	15"	15"	15"
<b>Freeboard</b>	22.5"	29"	27"	29"	29"
<b>Weight (hull only)</b>	2300	3100	3450	3650	3780
<b>Fuel capacity I/O - OB</b>	/70	/95	70	138	90/109
<b>Horsepower I/O-O/B</b>	/150	180/225	240/250	240/260	240/270

Specifications subject to change without notice



NOTE: ALL DEVICES ARE GROUNDED WITH A BLACK WIRE TO THE NEAREST GROUND TERMINAL BUS BAR. MANY OF THE GROUND WIRES ARE NOT DRAWN BECAUSE OF SPACE LIMITATIONS.  
FOR ENGINE / INSTRUMENT WIRING DIAGRAM REFER TO YOUR ENGINE MANUAL.

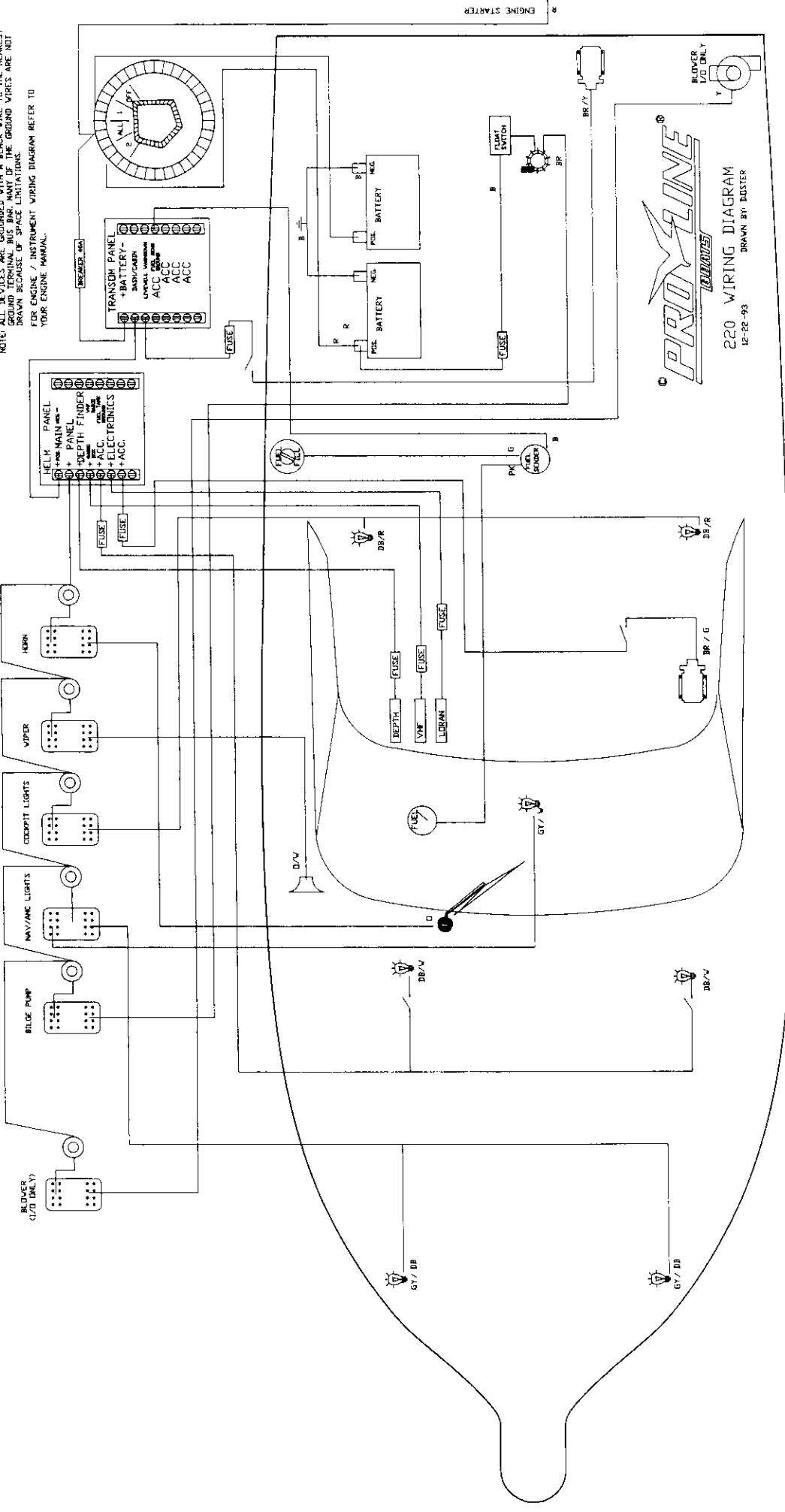

**PROXLINE**  
BOATS

220 WIRING DIAGRAM  
12-22-93  
DRAWN BY: DUSTER

ENGINE STARTER